

Gas Flow & Temperature Control

Objectives

- Identify components of gas flow and temperature control on the LC/MSD
- Describe the operation of the flow control module
- Describe the temperature control electronics

Functional Block Diagram

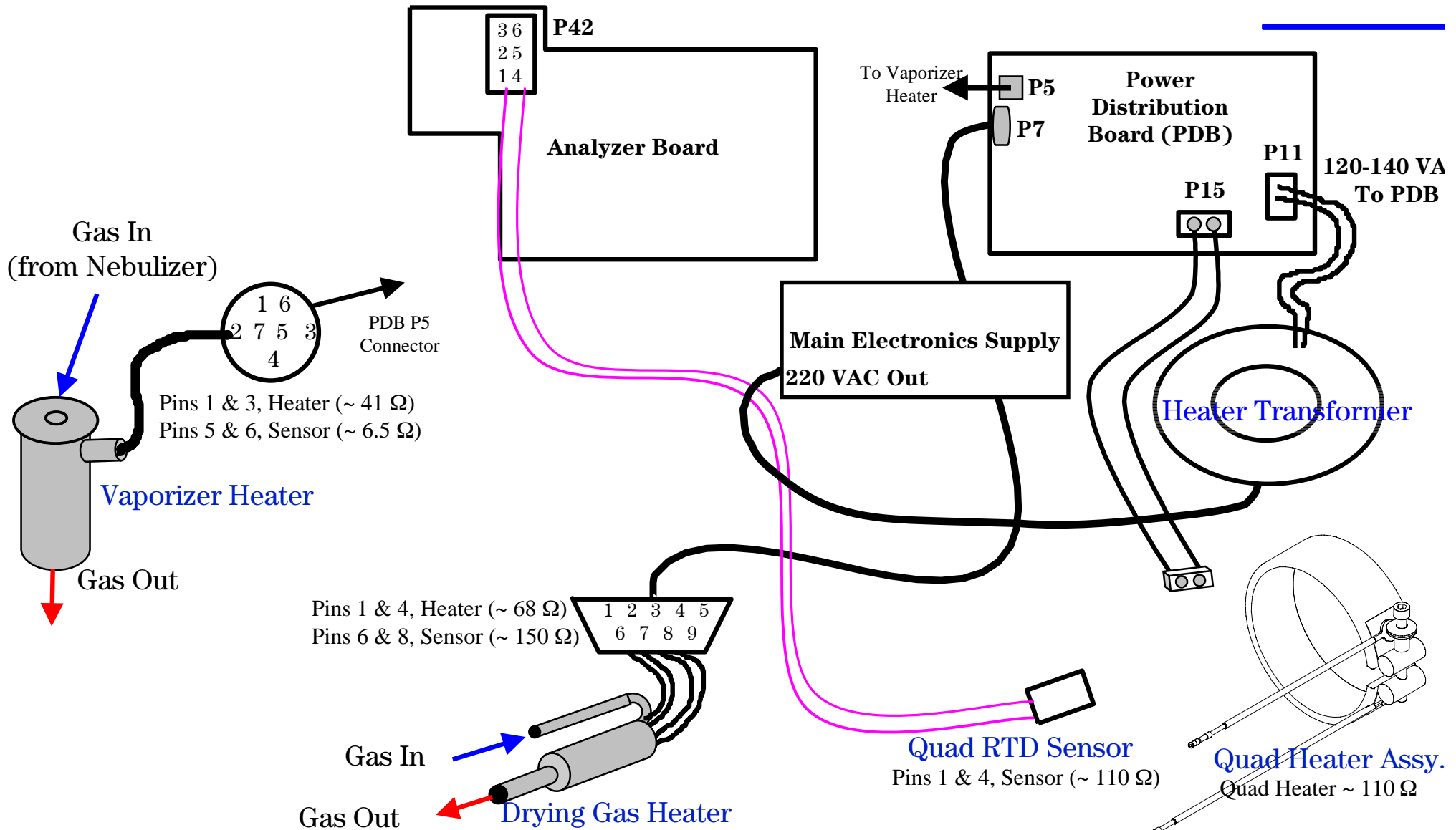

Power Distribution Board (PDB)

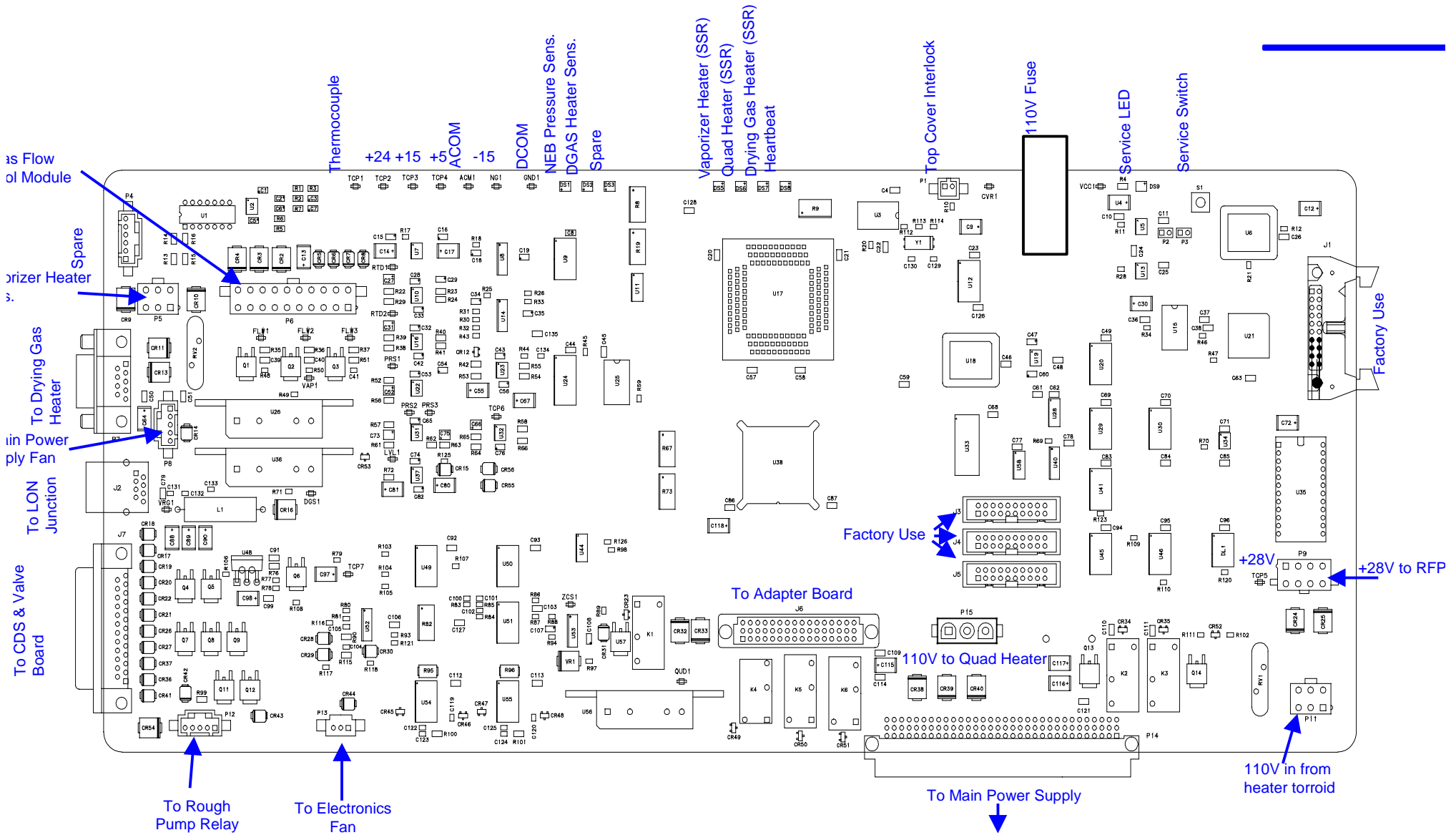

Gas Flow Control Module

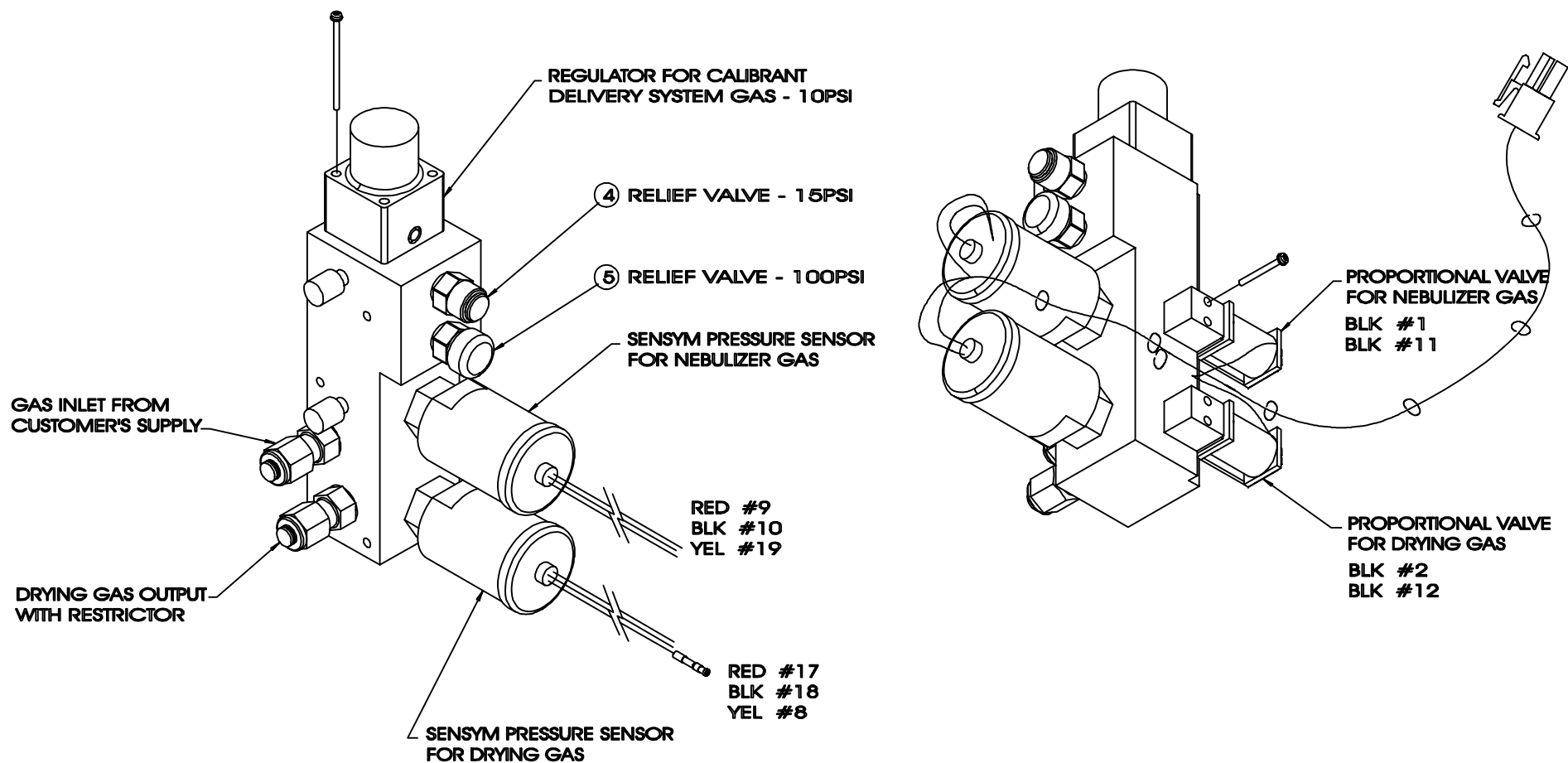

Desolvation Assembly

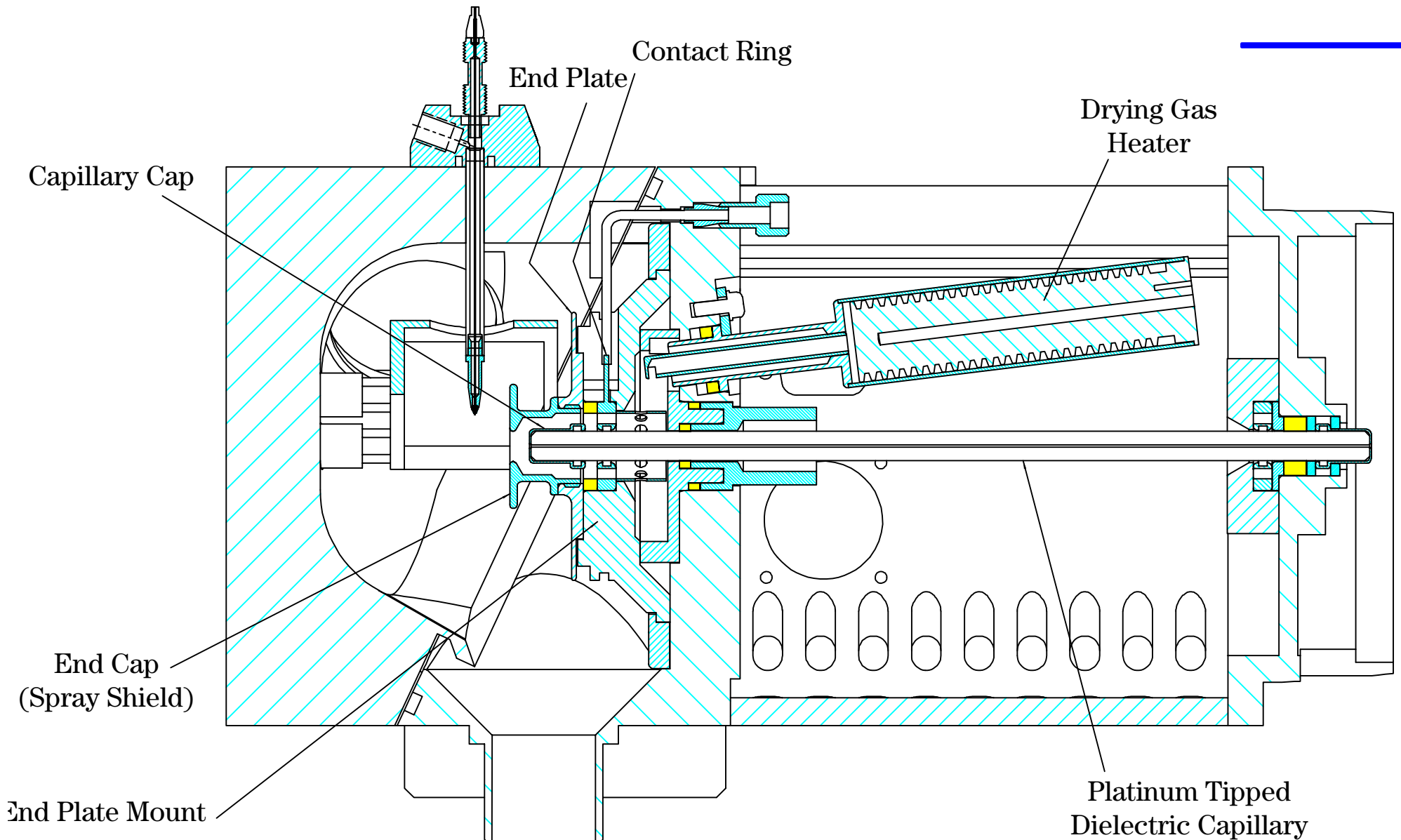

Quadrupole Heater Assembly

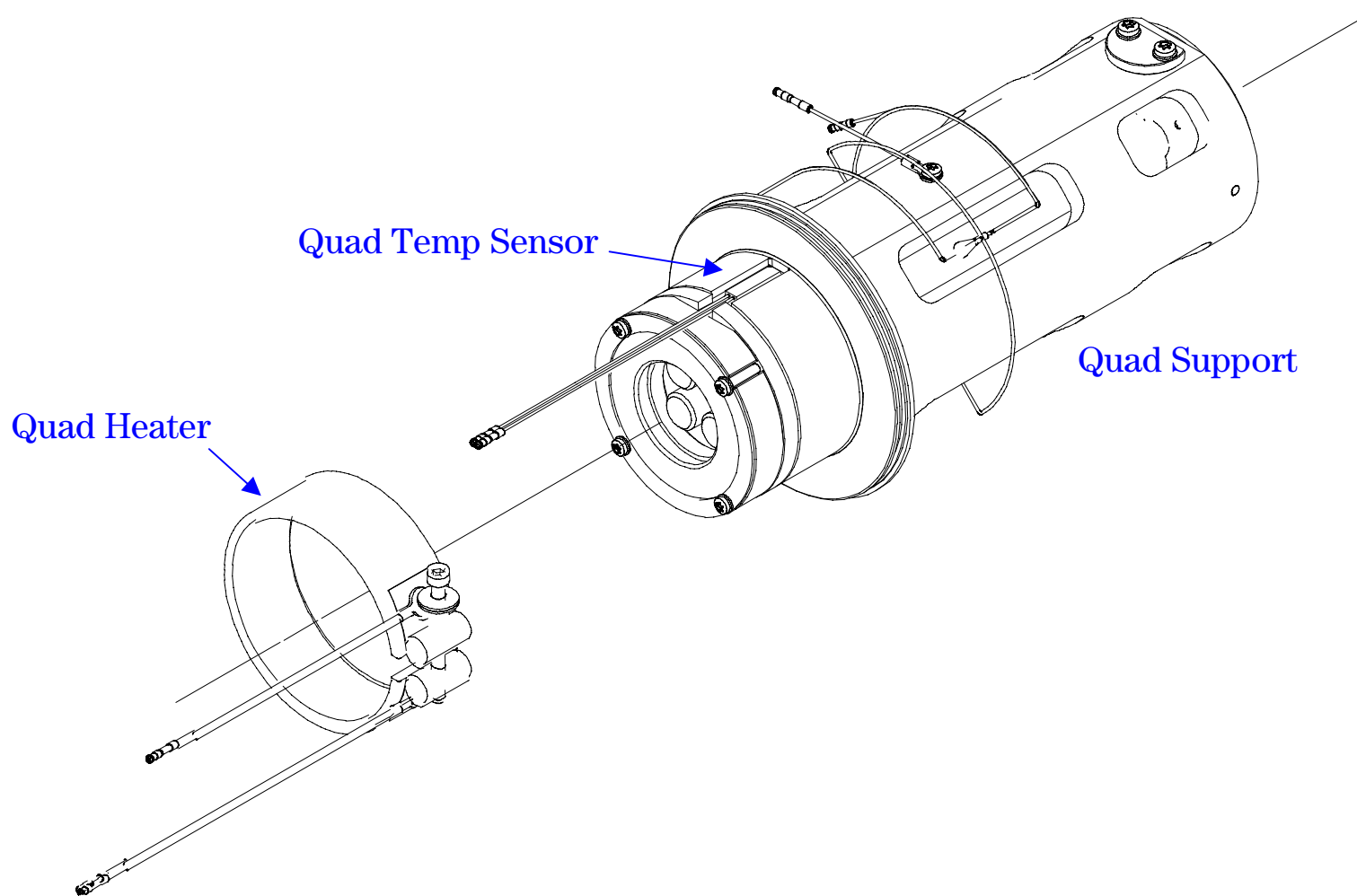

APCI Vaporizer Heater Assembly

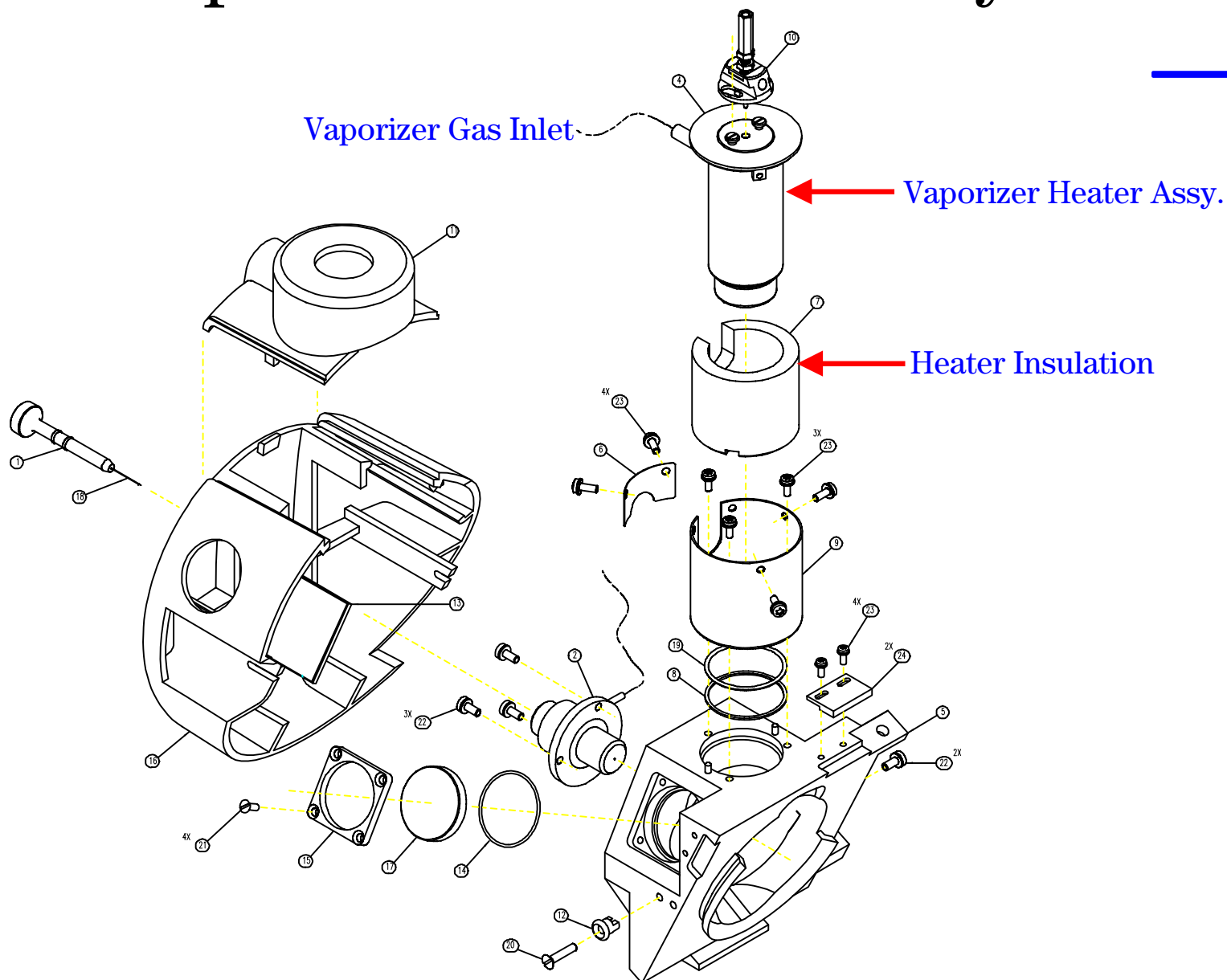

Temperature and Flow Control Readbacks in the ChemStation

MSD Spray Chamber [X]

Polarity: Positive Ionization Mode: **API-ES** [v]

Installed Spray Chamber: API-ES

Temperatures, Pressure, and Flow

	Actual	Setpoint	Maximum
Drying Gas Flow (l/min):	4.0	4.0	13.0
Nebulizer Pressure (psig):	20	20	60
Drying Gas Temperature (°C):	299	300	350
Vaporizer Temperature (°C):		N/A	N/A

Parameters

Capillary Voltage (V): **4000**

Corona Current (µA): **N/A**

Time Table

Time (min)	Parameter	Value
------------	-----------	-------

[Insert] [Append] [Cut] [Copy] [Paste]

[OK] [Cancel] [Help]

MSD Spray Chamber [X]

Polarity: Positive Ionization Mode: **APCI** [v]

Installed Spray Chamber: API-ES

Temperatures, Pressure, and Flow

	Actual	Setpoint	Maximum
Drying Gas Flow (l/min):	4.0	4.0	13.0
Nebulizer Pressure (psig):	60	60	60
Drying Gas Temperature (°C):	300	300	350
Vaporizer Temperature (°C):		350	500

Parameters

Capillary Voltage (V): **4000**

Corona Current (µA): **4.0**

Time Table

Time (min)	Parameter	Value
------------	-----------	-------

[Insert] [Append] [Cut] [Copy] [Paste]

[OK] [Cancel] [Help]

